

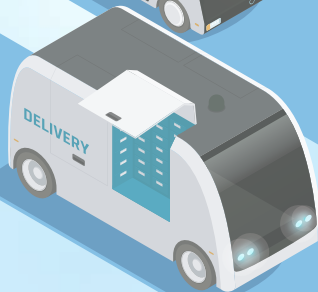

LOOPWAY

**A
MULTI
MODE
URBAN
RAPID
TRANSIT
FOR
YOUR
CITY**



**"THE URBAN
TRANSPORTATION
REVOLUTION
COMING TO YOUR
CITY."**

**EFFICIENT, FAST,
CONVENIENT,
SUSTAINABLE,
AND FEASIBLE
MASS RAPID
TRANSPORTATION
SYSTEM COMING
TO YOUR CITY.**



CONTENTS

INTRODUCTION

LOOPWAY SYSTEM INTRODUCTION

SERVICES OFFERED

BUILDING BLOCKS OF LOOPWAY SYSTEM

BIRTH OF NEW TRANSIT SYSTEM

HOW LOOPWAY TRANSIT WORKS

MODES OF LOOPWAY SYSTEM

ADVANTAGES OF LOOPWAY TRANSIT SYSTEM

BUILD (CAPEX)

OPERATE AND REVENUE (OPEX)

ABOUT LOOPWAY COMPANY

TUNNEL DEVELOPMENT - GBW

AUTONOMOUS STACK

POD DEVELOPMENT

DIGITAL APPS

SUBSTATION

HOW TO BUILD

PATH TO BUILD

SERVICES/SPECIAL PURPOSE VEHICLE



INTRODUCTION

Loopway is a Multi Mode Intelligent Transit System (ITS) In urban environment specifically designed for use in the Urban environment using Micro Tunnels for Right of Way (ROW), Fully Autonomous, Electric vehicles, and V2I platform Compared with other Mass Transit options like MRTS and BRTS, the Loopway system is more efficient to building and operate. The system enables private transit

- **50% Less Cost to Build**
- **Require 70% Less Land then traditional Mass Transit**
- Can Scale Vertically and can add more lanes without extra overhead
- **3X More Revenue per passenger**
- Multi-use capability for right of Way Lanes
- Deep Integration with Private Transit modes
- Indigenously developed and made in India technology
- Private stakeholders can participate in building the infrastructure reducing government capex
- Financially Viable Infrastructure

SERVICES



CONSULTING PROGRAM

For cities wondering if loopway is appropriate and wanting to explore more about the technology, our consulting program offers to the cities reports regarding build, operation and revenue potential. We provide a feasibility report, Viability Report (Cost to build, operate, and revenue), and a Detailed project report which includes specific substation plans, tunnel plans to build, route plans, and required software/hardware for the vehicles

FACILITATOR PROGRAM

loopway is designed to be a mixed mode transit system where the Private sector can be part of the system right from construction, we provide an entire legal framework to setup the company, raise required funding needed through Equity funding, Bond Holder funding, Private partnership funding, and Government funding. As facilitators, we also provide estimated revenue and ROI (Return On Investment) values, and interest payment on Bonds and dividends for equities.

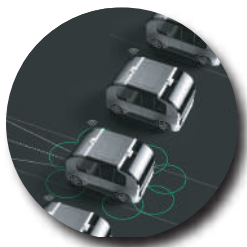

IMPLEMENTATION PROGRAM

This is a turn-key solution where we provide all aspects to build loopway system in your city. We partnered with companies that are leaders and innovators in their respective fields to execute the project. Loopway provides services to build tunnels, substations and install the required V2I sensors in the tunnel. We also provide needed software to run the platform (Traffic Management Software), Provide Autonomous Electric Vehicles and Digital Apps to integrate with the ticketing system.

OPERATE PROGRAM

Once the system is built, we provide services and training to operate and maintain the system efficiently. As operators, we integrate the system with ticketing and payment gateways. Provide digital apps for seamless integration to the platform



WHAT IS LOOPWAY SYSTEM

LOOPWAY SYSTEM is a rethinking of how a Mass Transit system and **Right of Way** (ROW) should work efficiently adapting new advancements in Transport technology. The system is an intersection of different domains mainly four fundamental concepts described below

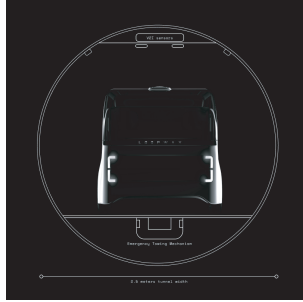

TUNNELS

Building Tunnels for the use of roadways or transit are expensive mainly due to the size of the tunnel needed. A two way road tunnel needs atleast 8 meters tunnel diameter and a typical metro tunnel is around 6.0 Diameter. Cost of building tunnel is exponential to diameter of the tunnel.

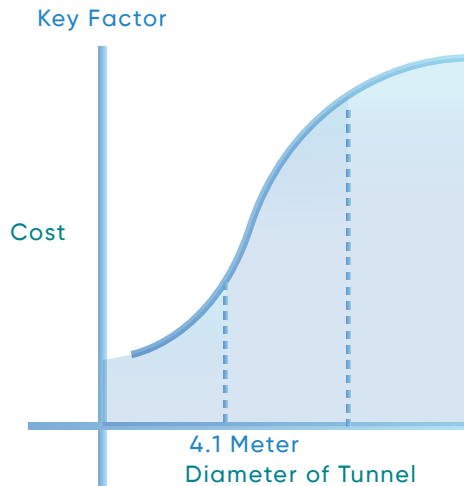

A Key to make tunneling cost less is to make the diameter to be smaller

COMPONENTS OF LOOPWAY SYSTEM

Autonomous Vehicles

Over the past few years there has been a huge advancements on Autonomous Vehicle Development and Sensor Suite. the use of autonomous vehicles has several advantages like less operating cost, ability to navigate in tight places and with integration of V2V and V2I, enabling us to eliminate signals and intersections

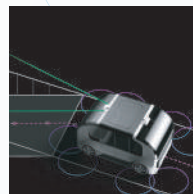

Emission Free Vehicles(EV/Green Hydrogen)

Green Vehicles like EV's and Green-hydrogen have made a lot of progress and are projected there is a great push across the world to move to a sustainable future with EVs. One of main advantage of the vehicle are zero pipe emissions and cost of vehicles are reducing drastically.



Digital Platform

With the advent of mobile revolution from the past 10 years, now it is easier then ever to make rapid connections with the passengers and really scale and plan the transit system. Most of the passengers are already comfortable with P2P commute and rides are available at their finger tips.



Substation/V2I Environment

With revolution in Sensor suite, Robotics and communication advancement like 5G/LiFi, substations can be completely developed to be Autonomous with the highest safety standards. With Traffic Management system, we can integrate private transit system to mass transit system . The Substation can be integrated with road network enabling seamless end-mile connectivity an easy way to switch between tunnel and road network for seamless vehicle movement.



HOW IT WORKS

All the technologies explained before are complementary to each other and we can achieve a super efficient system by using them together. Here are some advantages of each system and how it complements the other subsystems

A **MICRO TUNNEL** Closed and Controlled nature of Tunnels make it ideal to assist in Autonomous Vehicles. With the predictive nature of the tunnel environments we can achieve fully autonomous vehicles with out human control and attain greater speeds safety and through put of Right Of Way.

Autonomous Vehicles with The advent of Autonomous vehicles taking tight turns easily and with less human error in the system, we can make the road width needed for travel to be 9 feet, which reduces the diameter of the tunnel needed. A 4.1 meter tunnel is sufficient as compared to 6 meter tunnel needed for a Metro reducing the cost of tunnel 2-fold

Vertical Substation/Digital Platform With the micro-mobility offered by EVs, substations can be truly built vertically taking less real estate and able to connect to underlying tunnels easily. A control room in the substation also enables hyper-connectivity for logistics and seamless integration with the city's existing transit system

Emission Free vehicles With the pollution free nature of vehicles, they can be operated in a closed environment with out any expensive ventilation system needed, which in-turn reduces the size of tunnel and ventilation needed for closed environments

HOW IT WORKS

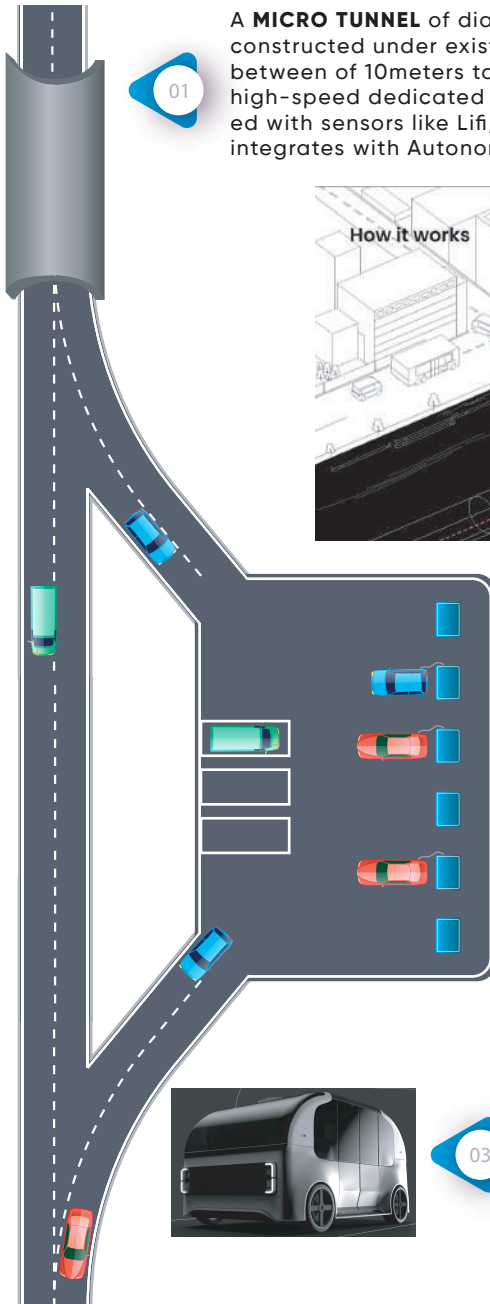

01

A **MICRO TUNNEL** of diameter 3.7meter (inner diameter) is constructed under existing road infrastructure at a depth between of 10meters to 30 meters which will be used as a high-speed dedicated Right Of Way. The Tunnel is connect-ed with sensors like Lifi, Lidars, and Cameras which integrates with Autonomous Traffic Management System.

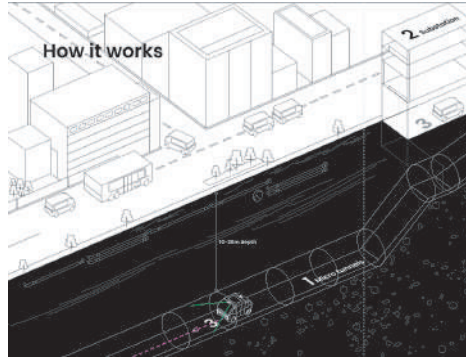

02

A **SUBSTATION** is developed on the surface and consists of multiple levels with a ramp connecting different levels and connecting underlying tunnels. Each level is assigned to different modes of transit systems like Mass Transit, Private Transit, and Logistics Center. The ground level of the substation is connected to the road network enabling private transit to enter the tunnel entry ramp.

03



FULLY AUTONOMOUS EVs are used for station-to-station transit systems same as any traditional MRTS or BRTS system. Vehicles which are fitted with autonomous capabilities and which are controlled by Traffic Mangement System will be used for transit

MULTI MODE TRANSIT SYSTEM (MASS TRANSIT)

Inherit nature of **LOOPWAY RAPID TRANSIT SYSTEM** enables Multi mode transit system with controlled Shared ROW (Right of Way) and Micro mobility possible in a Mass transit environment.

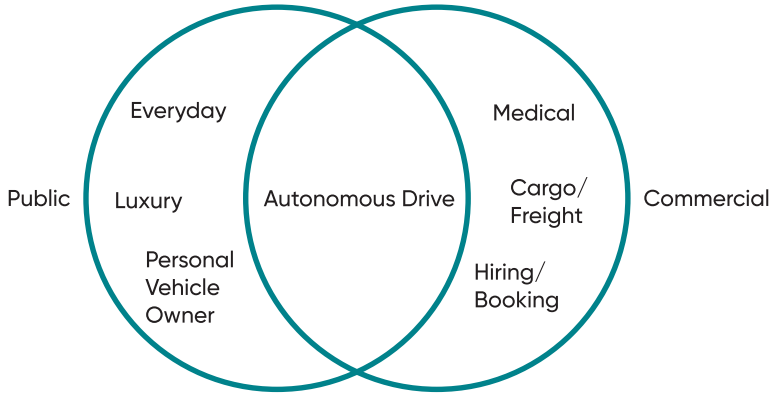

Shared Mobility

More budget-friendly associated with regular Mass transit which are similar to existing Rapid Transit systems like MRTS and BRTS, where several people share the same POD. Our cars are capable of carrying up to 12 passengers on a standing basis and provide seating up to 6 passengers



Premium Shared Mobility

Taking advantage of our micro-mobility capability, capable of catering to different sections of passengers, this premium shared mobility can be provided with dedicated and comfortable seats. These are more catered for elderly passengers, passengers with special needed, and passengers who want more comfortable travel



Dedicated Mobility

The system can also cater to passengers who are in groups or need of on-demand travel, the whole POD can be booked well in advance. This is more convenient and provides a faster way than traditional transit system

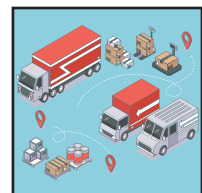

MULTI-MODE TRANSIT SYSTEM (PRIVATE TRANSIT)

Private Taxi Mobility

The Loopway system is developed as such private vehicles with retrofitted autonomous sensor suites can use ROW. This enables true End-End transit with no last mile issues plagued in MRTS and BRTS systems. Passengers can book a private cab, which picks them from their home, drives to the nearest substation, and autonomously merges in to the tunnel. In a Tunnel, the vehicle travels in Autonomous mode and makes exit nearest to the destination. The vehicle proceeds to the destination dropping off passengers. This enhances both passenger experience and makes Cab truly running to the capacity and in our estimates it increases 3X trips of regular cabs.

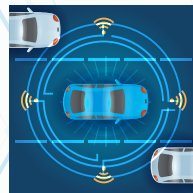

Emergency Medical Services

Our System enables deep integration with EMS like Ambulance Services, Organ and Blood Transport, which will be given the highest priority in the Right Of Way tunnels and will be integrated to the nearest hospitals across the city.



Logistics

Our POD platform used for developing passenger travel will be used for carrying Goods across the city with minimal modification. Our substation can be leased out to Logistics companies like DHL/FedEx /Courier Services, enabling Rapid intercity transport systems across the city.



Expanded Business Services

Through our Digital Apps, Loopway system can be expanded to several time critical businesses like Food services like Swiggy/Zomato. This will revolutionize several other businesses which are limited to the proximity of physical goods to reach customers in a timely manner.



HIGHLY AUTONOMOUS SYSTEM

Using our state of art autonomous system, we are able to achieve lower operating cost , higher safety, higher utilization of vehicles and fully integrated with digital apps.



SEAMLESS MERGING TO HIGH SPEED LANE

Loopway System uses Autonomous Entry/Exit Ramps for Vehicles to enter and exit tunnels. No need of intersection, eliminating need for signals. Direct path between source to destination station without any intermediate stops required. Eliminating signals, waiting reduces duration 2X with similar speed

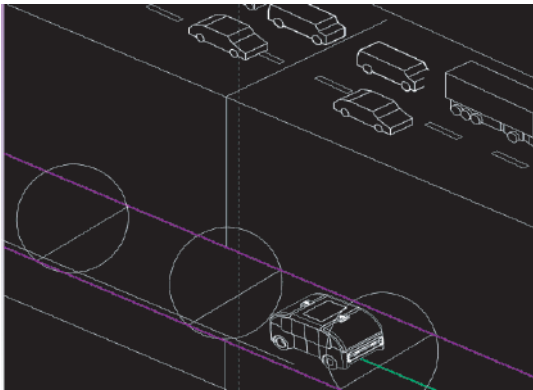

MUTLIPLE LEVELS OF SUBSTATION

Loopway system enables substation to build verticals taking advantages of micro mobility . Each level in substation can be dedicated to specific transit mode like mass transit, dedicated transit, private transit and logistics making substation more revenue generating platform. Operating multiple modes of transit from centralized location reduces overall operating cost of the system and increases revenue.



INTEGRATED ROADS

Enabled easy ramp in / ramp out for private transit vehicles (like taxis, private vehicles) . Provides higher degree of end mile connectivity.

SAFETY

Higher level safety then human operators. Multiple redundancy system for safety, Traffic monitoring system for entire system, vehicle safety control system for localized safety



BUILD

Building infrastructure is a huge investment upfront cost and the Loopway system is developed in such a way that we minimize the upfront cost by optimizing several parts of the build parts, especially in ROW construction, Substation, and Land Acquisition costs.

Right Of Way:

We use Tunnels as ROW instead of Elevated Road or Rail Corridors. Micro Tunnels (4m diameter) will be approximately the same cost as any Elevated road/rail and will have added advantage of constructing more ROWs deeper without much additional as compared to Elevated roads. The Land needed 3X Less than Elevated Corridors

Substation construction:

Substations are built and can be customized to build in a very small footprint by going vertical. Our Micro Mobility POD's used in the Loopway system can easily be rolled out and rolled into the ROW and can use circular ramps enabling Vertical substations instead of horizontal substations as required in MRTS/BRTS. This reduces the amount of real state needed to be very minimum with around 2X than traditional substations and costs similar to any traditional substation.

Land Acquisition:

Loopway System generally uses way lot of real estate than a traditional system, based on the above two factors, this kind of system only required one-fifth of real estate than MRTS, reducing the cost for acquisition 5x less than traditional requirements

Vehicles:

The Autonomous POD's is developed on a Unified platform from an India-made Electric platform like the Mahindra-Mahindra INGLO platform with different chassis per requirements, which is more cost-effective than traditional monolithic Metro Trams. They are easier to maintain, repair, and replace. For a typically 4000 passengers/hour/Km, we only need around around 100 vehicles making 3x Trips with 12 Passengers in each POD which are a fraction of the cost compared to metro cars.

COMPARISON WITH TRADITIONAL MRTS AND BRTS

As loopway is a kind of mixed mode transit, to make apples to apple comparison, we calculated the cost associated with different systems like MRTS and BRTS, based on 10KM, Two Way, 5 Substations, and 4000 Pax/hour capacity

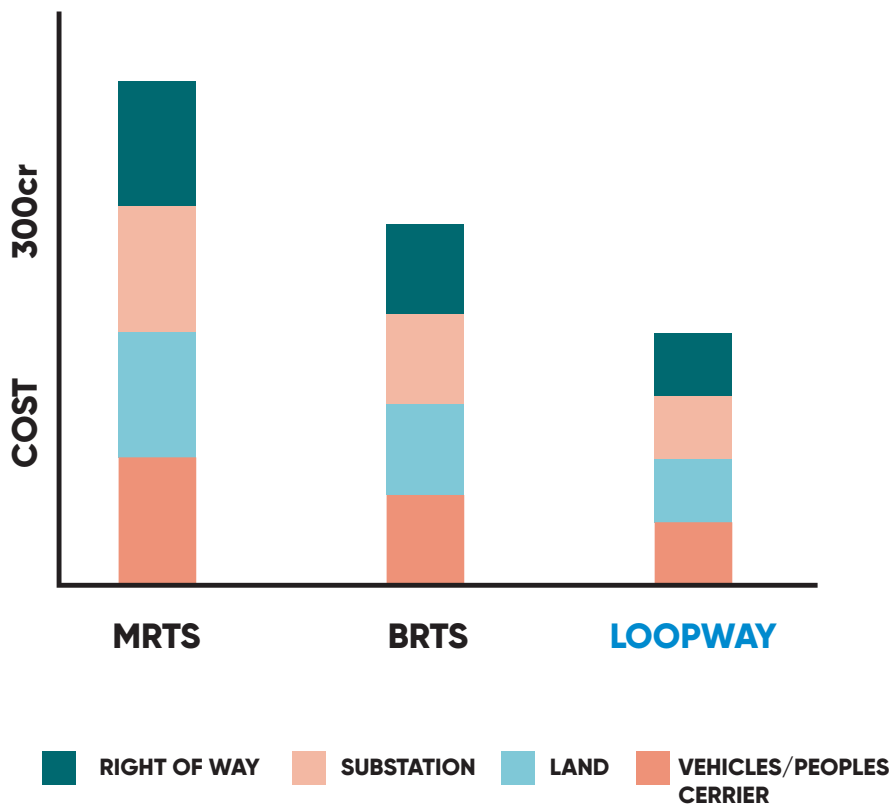

OPERATING COST AND REVENUE

Loopway is build on foundation of making Private Public Partnership an integral part of the system and have deep integration between private access to public ROW maximizing revenue potential of overall Transit system.

Operating a Tunnel are way cost effective than operating over the ground road ways because of Tunnel inherently is shielded for climate like Rain, Sun, Wind and Dust. Tunnels also last way longer than any traditional over the ground infrastructure. As the platform for the vehicles are adapted from consumer vehicles like Mahindra Inglo, they are more reliable and cost effective because of economics of scale applied for consumer vehicles as compared to specialized Trams and Buses.

Revenue Generating from Multimode for a typically system where **50%** public mass transit traffic and **50 %** for private transit traffic

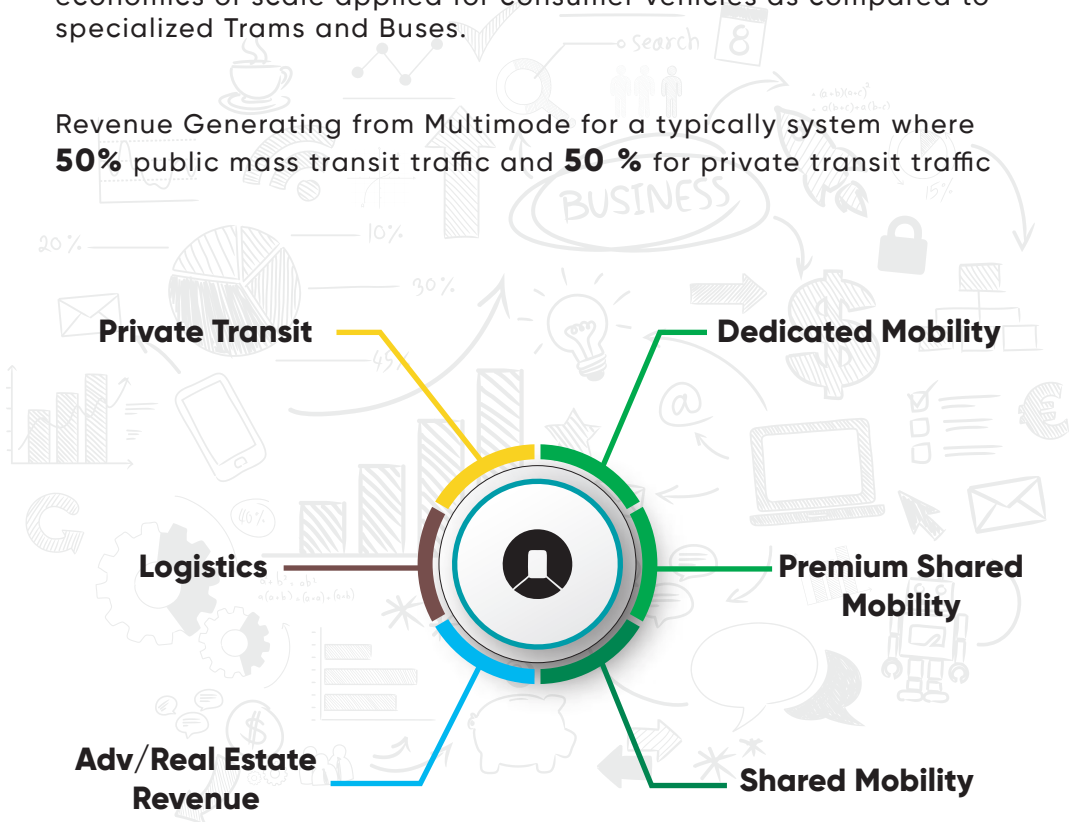

OPERATING/REVENUE COMPARISON

The real capability of Loopway system is its ability to generate higher revenue per passenger and making operating cost as minimal as possible. For a hypothetical comparison between typical general availability mass transit system

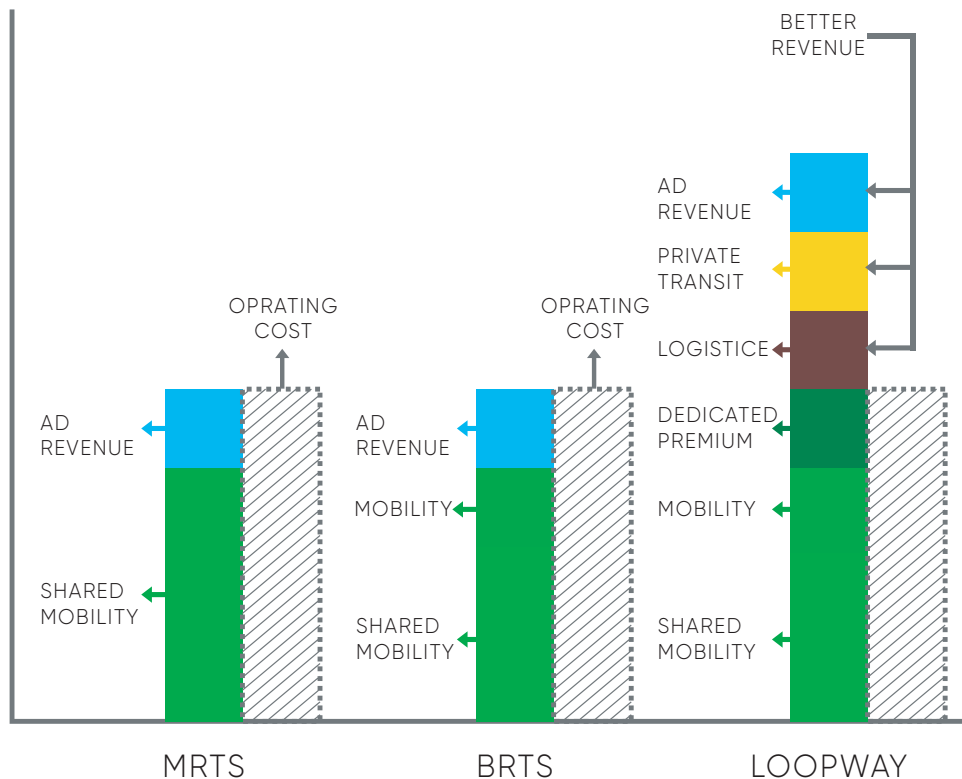

 **SHARED MOBILITY**

 **MOBILITY**

 **DEDICATED**

 **AD REVENUE**

 **LOGISTICS**

 **PRIVATE TRANSIT**



VISION TO REALITY

Loopway is working hard for the vision to take our Loopway Rapid Transit System to reality. As the system is complex, we have partnered with various companies and setup the company to have worldwide presence for talent. Loopway is branched out from our parent company GBW (Tunneling) and formed legal US Entity for Software development and POD development.

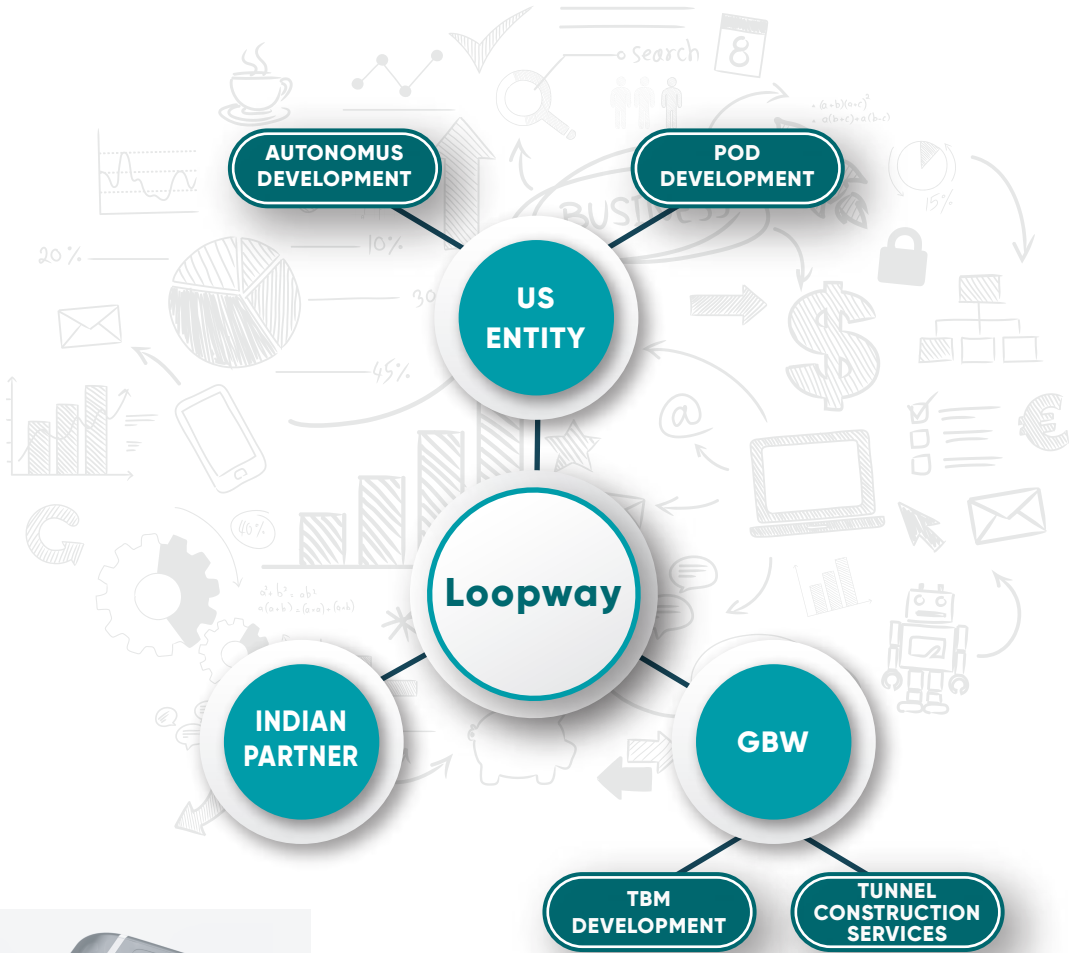

LOOPWAY INFRASTRUCTURE STACK

Bird eye view of entire system and how they interact with each other. Overview of how we partnered different industry leaders across different domains to make this reality

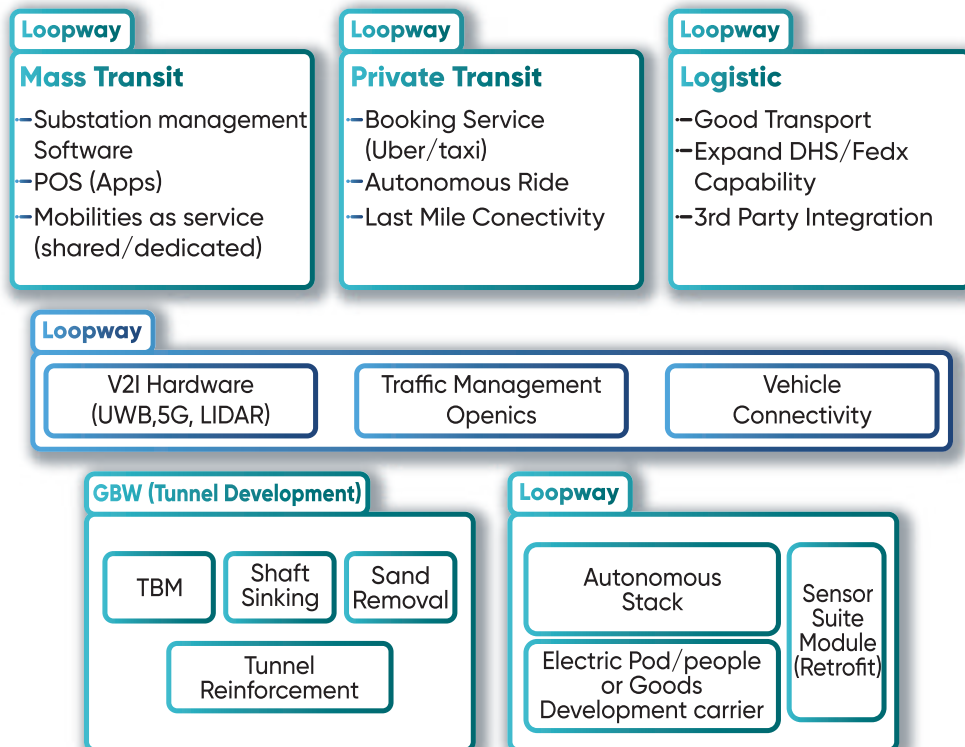

GBW(GEETHA BOREWELLS PVT LTD)

- Had 36 Years of experience working in irrigation and mining
- Worked with several Government agencies like AMD(Atomic Mineral Directorate) , UCIL (Uranium Corporation India Limited), Singareni Collieries, Hutti Gold Mines, Nepal Water Board) for the need of exploration and tunnel ventilation.
- Worked with several private companies including L&T, CE Construction, and AFCONS, for the Shaft Sinking of diameters up to 1.8 Meter
- Indigenous developed several Vertical Tunnel Boring Machine using Pneumatic Cluster Drill Bit, One of the fastest drilling in the industry
- Experienced in manufacturing Tunnel Boring Machines from Ground-Up
- GBW did at least 30,000 feet of 1.8meter vertical tunnels (vertical tunnels are one of the toughest in the Tunneling business)

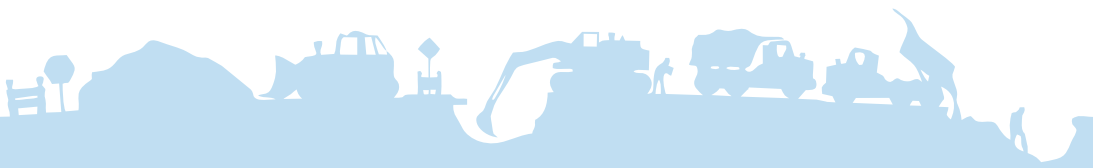
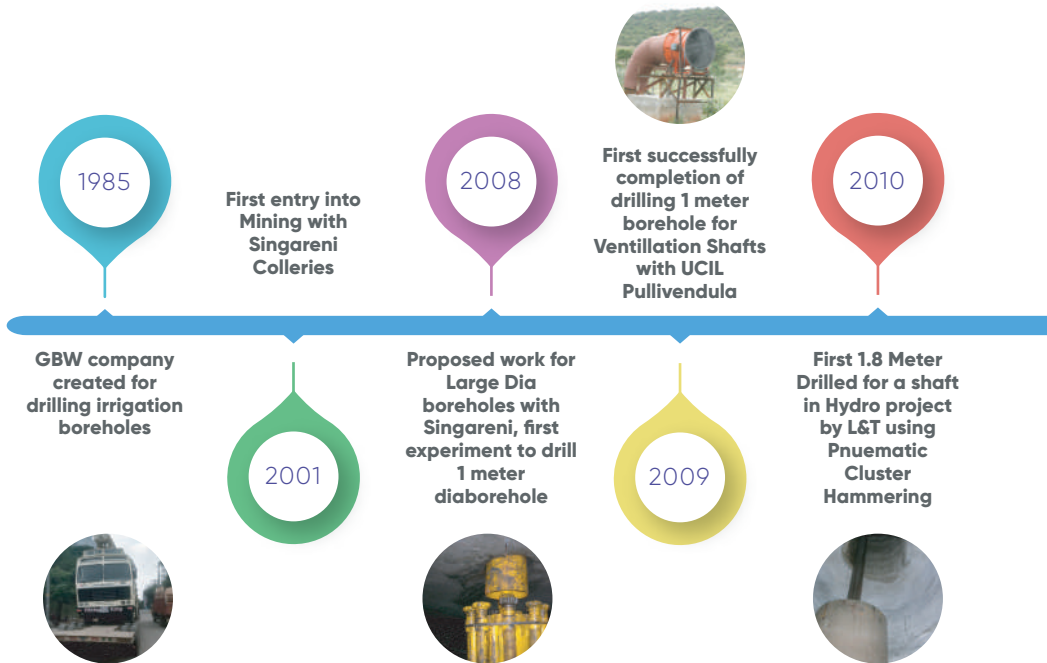

CUSTOM TBM

We have re-engineered entire Tunnel Boring Machines and optimized them for Efficient Drilling using Pneumatic Bit, Electrifying and autonomous robotic Arm for reinforcement which are quiet and suitable for Urban Environments.

- Design and Developing Custom Tunnel Boring Machine for Urban Usage
- Optimized to use in Urban Environment
- Totally Electrified to reduce pollution and easier to work in Tunnels as Electricity is readily available
- Higher penetration depths than standard TBM (which uses Rotary Drill Bits)
- Modularized, reusable TBM for easy assembling, easy disassembling, and best cost optimization
- locally manufactured parts enabling easy maintenance
- Developing an efficient Autonomous Robotic Arm for Tunnel Reinforcement (Cross over knowledge from our Autonomous team)

Projects with Hutti Gold Mines, Lanco , Singareni Collieries, UCIL and Mosha Varsha for drilling large dia boreholes upto 1.8 meter for Ventillation purposes



First investment in Loopway for helping it setting up basic infrastructure and analyzing tunnel under

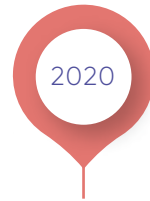

Expansion to Nepal water board and tunnel to surface boreholes manufactured tunnel to surface boreholes



Continue working on Shaft sinking projects for CE constructions, UCIL

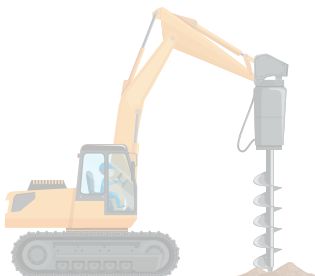
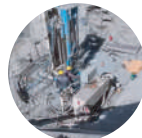

AUTONOMOUS DEVELOPMENT

One of the key components for Loopway Transit System to work is the ability to navigate in smaller tunnels Autonomously. Most of the Autonomous stack is not optimized to work in Tunnels and we have completely started developing from Ground-Up. This needs several teams to work and we partnered and contracted other Industry leaders

For DBW (Drive By Wire), we contracted ARAI (Automotive Research Association of India)



Using industry-leading Sensor for LiDAR, Cameras, IMU, and all required hardware needed for Autonomous Driving

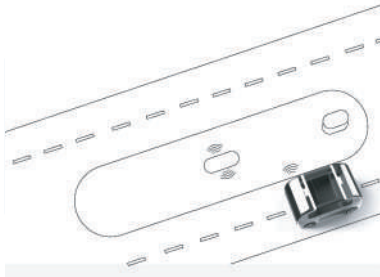

Mostly developed Homegrown (Indigenous) software stack with Engineering all over the world.



US Entity of Loopway is contributing to and leading the development



POD DEVELOPMENT

Loopway is developing a purpose-built Fully Autonomous POD capable of transporting from 4 passengers up to 12 passengers at a time and also a Cargo POD for goods carrying. Taking into consideration the specific needs of the system we are developing different POD bodies for different use cases.

We partnered with Mahindra Electric for using their electric platform



Using State Of Art 3D Printing for quickly prototyping vehicles

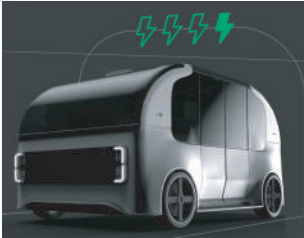

Partnered with Mahindra and Mahindra Electric division to provide the needed Electric Platform



POD with sliding doors has been designed for easy passenger boarding and debarking

Different Seat Configuration to enable Shared Mobility, Dedicated Mobility and Goods Carries is been developed



Used concepts of Micro factories to quickly develop and deploy POD's as per needs



Unified platform to be used for both Goods and Passengers



Designed specifically to navigate in tunnels and with additional safety features for tunnel-specific use cases

SUBSTATION DESIGN

Substations are an important part of overall integration which enables seamless integration between Private and Public transit systems. We are designing the substation which is capable of integrating Autonomous driving with the highest safety standards and using less real estate. The stations are also designed to grow vertically for high-volume places without any more real estate needed.

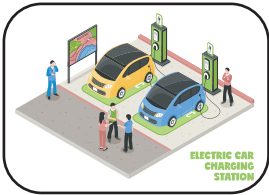

- ▶ Capacity to serve more than from **100** to **2000** passengers per hour
- ▶ Integrated charging stations

Fully autonomous navigation for safety

Easy ramp in / ramp out for private transit to enter and exit tunnels

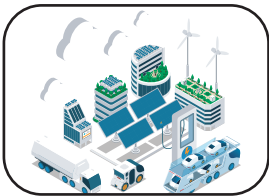
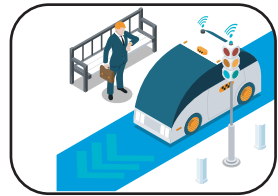

- ▶ Less disruption while building and operating the station
- ▶ Possible to build in very small spaces and in busy places

TRAFFIC CONTROL MANAGEMENT SYSTEMS

To increase safety of the entire system, Loopway is developing Traffic Control Management System which guides Autonomous Vehicles throughout the system. TCMS is the backbone of the entire system which integrates and monitors all Autonomous Vehicles in the system

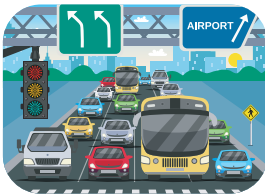
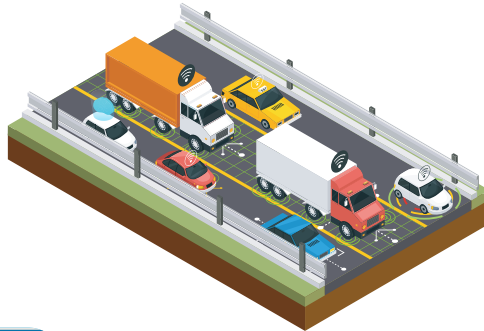

- ▶ Manages entire traffic in a network of tunnels
- ▶ Assist in merging and exit of AVs to the tunnels, which eliminates the need for Signaling and improves throughput

The throughput using Autonomous Vehicle combined with TCMS increases the capacity at least by **2X** times

Guides the vehicles in substation and schedules autonomous charging increasing battery life cycle and efficient use of the vehicles



- ▶ Integrates with Point of Sales for mass transit and guides passengers to the appropriate vehicle
- ▶ Manages parking assignments

Additional safety for the vehicles by central monitoring and controlling all vehicles in the system



DIGITAL PLATFORM

For seamless system integration, we custom developed several mobile apps and desktop apps

POS(point of sale apps to book shared/dedicated mobility)

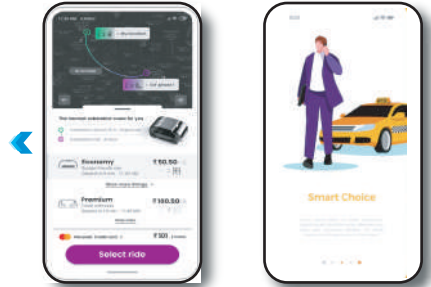

➤ Private Transit App
(For end-end last mile journey)

Human Machine Interface for POD tailor made for shared mobility and dedicated mobility

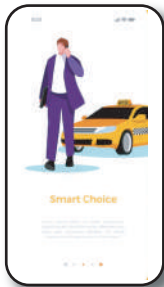
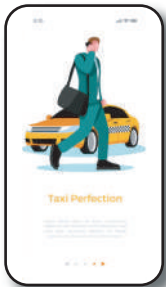

➤ Auxiliary Services has been integrated in all apps to provide seamless customer services including food, and integration with Ads across the board

TEST BED

Loopway is building state of the art Testbed for the entire system, including micro tunnels, substations, a control room, and Autonomous Vehicles on 64 acres of land (2.8Million Sqft). The TestBed will be used for Data Acquisition purposes for AI Training, Testing the MicroTunnel Ventilation system and will serve as a demonstration for all intrested stakeholders.

Substation 1

A fully functional station with entry and exit ramps to the tunnel, Autonomous navigation, an Electric Charging station, and Passenger Mass Transit PODs.



Tunnel

A 3.6 meter Inner diameter cut-and-cover tunnel is been developed with total linear length of 2.5KM with V2X sensors integrated through out the tunnel for seamless communication.



Substation 2

Developed to demonstrate the integration of Private Transit Systems like Logistics, EMS Vehicles, and Taxi Services.



Control Station

State of Art control room demonstration of all traffic control setup, connected by Fiber communication demonstrating how a typical control room would be operated.

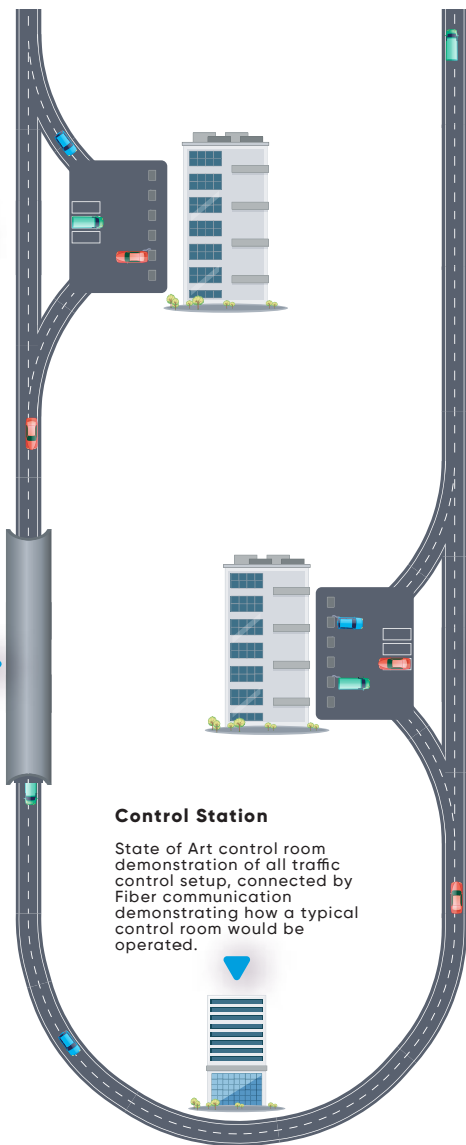

PATH TO BUILD FOR YOUR CITY

Loopway would be the first financially feasible infrastructure project against any public transportation system that exists. Due to the nature of deep integration between private stakeholders, we can build the entire system using Special Purpose Investment Vehicle to plan, fund, build, and operate.

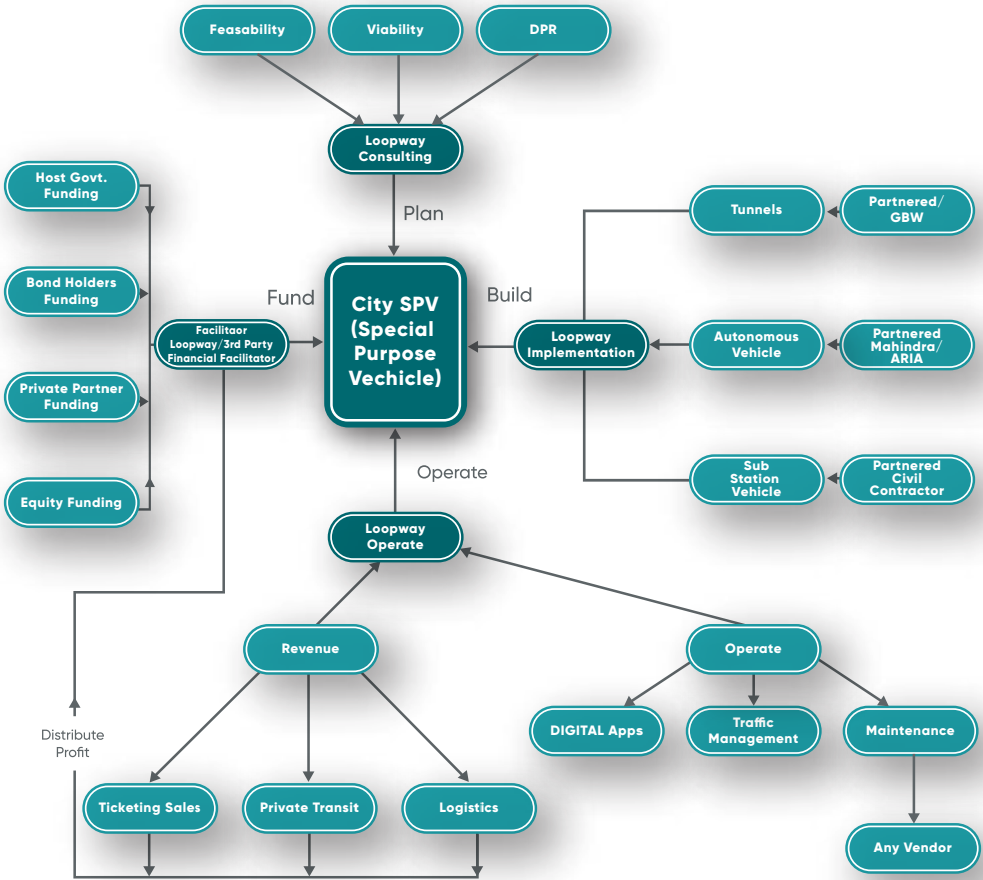

LOOPWAY TURN-KEY SOLUTION FOR ENTIRE SYSTEM

Consulting Program

PLAN

Our consulting program assists your city in feasibility studies, financial reports, and detailed project reports. We produce detailed plans including feasible routes, no of substations required, tunnel specifications, soil reports, and estimated final costs for the entire system to build.

Facilitator Program

FUND

As facilitators, we provide an entire legal framework to set up the company and raise the required funding needed through Equity funding, Bond Holder funding, Private partnership funding, and Government funding. As facilitators, we also provide estimated revenue and ROI (Return On Investment) values, and interest payment on Bonds and dividends for equities.

Implementation Program

BUILD

This is a turn-key solution where we provide all aspects to build loopway system in your city. We partnered with companies that are leaders and innovators in their respective fields to execute the project. Loopway provides services to build tunnels, build substations and fit with the required V2I sensor to the tunnel. We will also provide needed software to run the platform (Traffic Management Software), Provide Autonomous Electric Vehicles and Digital Apps to integrate with the ticketing system.

Operate Program

Once the system is built, we provide services and training to operate and maintain the system efficiently. As operators, we integrate the system with ticketing and payment gateways



CURRENT PROGRESS

Loopway is a complex system with multiple disciplines involved across different domains mainly in Autonomous Vehicles, Tunnel Boring machines, and Electric PODs. For the past three years Loopway is working hard by developing, partnering, and testing related technologies.

Some of the milestones until now are

- Partnered with ARAI, Mahindra Electric, and IITH Tihan
- Architected Autonomous Stack from GroundUp to work exclusively in Tunnels
- Developing Fully Autonomous Vehicles and Sensor Module needed
- Acquired 1.8M TBM and expanded to dig 4meter Dia Tunnels

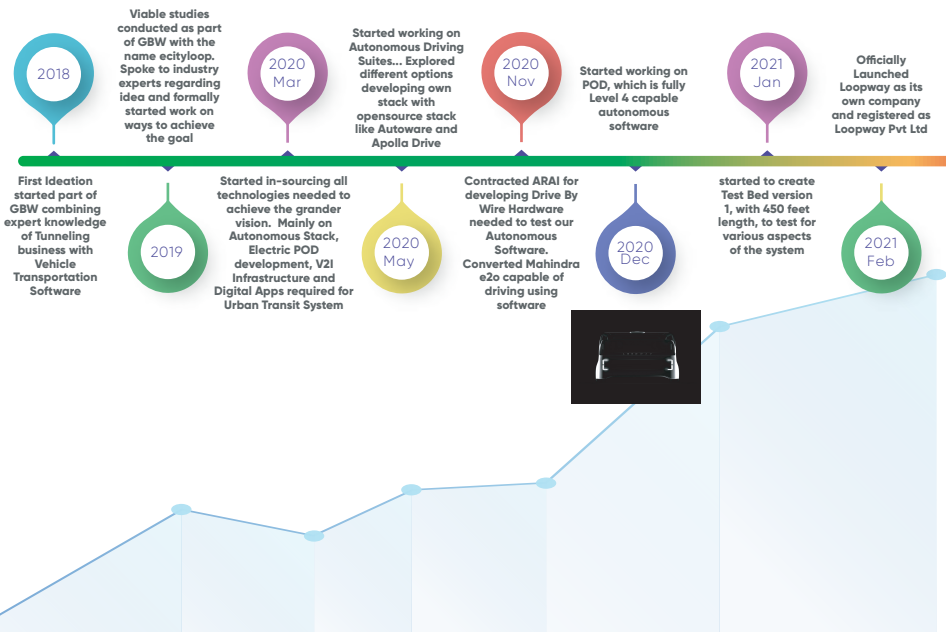

FUTURE OF LOOPWAY

Our focus is solely on We are intent to invest more in R&D developing loopway technologies and expect to complete

Future Milestones

- Complete proposed Testbed for testing and demonstration
- Release v1 version of Autonomous Software Stack
- Complete Electric Autonomous POD
- Test Next-Gen Tunnel Boring Machine for Rapid Tunnel Development

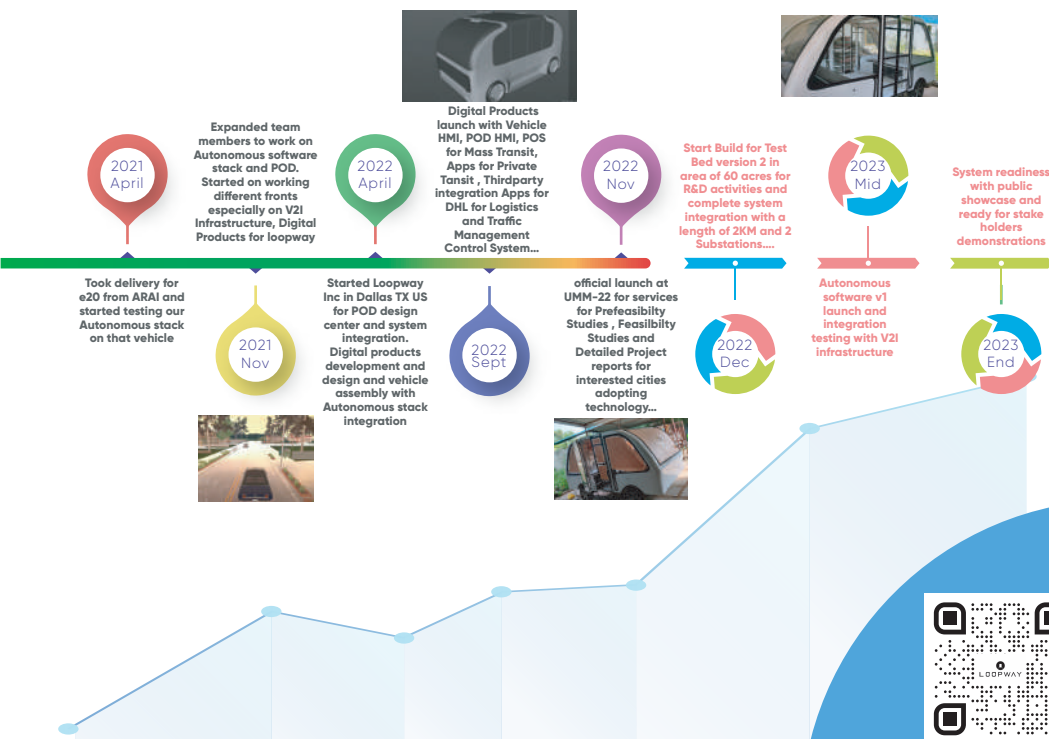

Loopway Rapid Transit System is a novel approach to building and sharing Right Of Way using Micro Tunnels and Autonomous Electric Vehicles enabling an efficient, sustainable, and financial viable transit system for future Urban Transit



Email: info@loopway.in

PH NO.: +91 9391018894

Plot No 7, Sainagar Colony, Rd No:4, Hyderabad, Telangana 500068

www.loopway.in

